

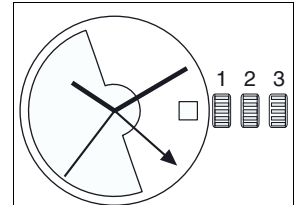

11 ½<sup>'''</sup> ETA 2893-2

CT 2893-2 ESI 481273 08 03.09.2012

11 ½<sup>'''</sup> Ø 25,60 mm



Movement height	Altura sobre máquina	Altezza sopra movimento	4,10 mm
Running time	Reserva de marcha	Riserva di marcia	42 h
Number of jewels	Número de piedras	Numero di pietre	21
Angle lift of balance	Ángulo de alzamiento	Angolo di alzamento	51°
Frequency	Frecuencia	Frequenza	28'800 Hz

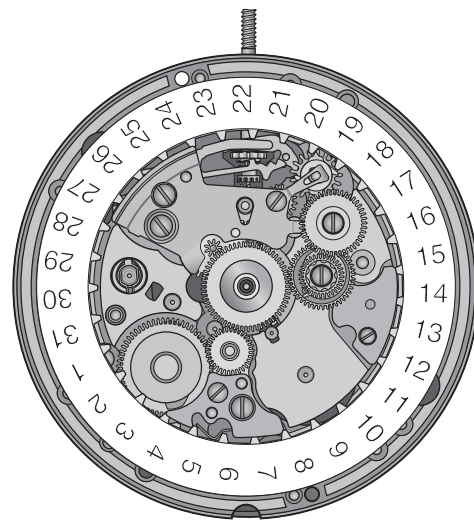
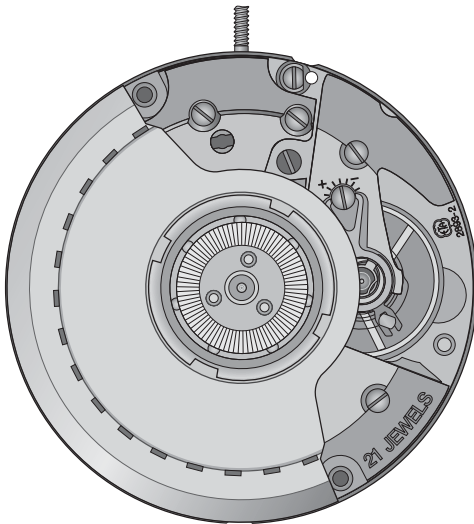

The repair and reconditioning work must only be performed by properly trained personnel.  
Las tareas de reparación y revisión sólo deben ser llevadas a cabo por personal debidamente formado.  
I lavori di riparazione e di revisione devono essere eseguiti esclusivamente da personale adeguatamente formato.



## General information



**Before** starting work, please study this "Technical communication" carefully.



Eye protection is obligatory for all operations / work on the movement!



ETA SA disclaims any liability in case of damage arising from failure to observe this "Technical communication".

## Environmental protection requirements



**The legal provisions relating to waste handling and disposal must be observed in all operations / work on the movements!**

In particular, lubricating and cleaning products harmful to the environment must be disposed of in accordance with the rules!



**Substances prone to cause water pollution** must be stored, transported, collected and disposed of in appropriate vessels.

**Under no circumstances must they pollute the soil or be poured into sewage systems!**

## Explanation of symbols



**Caution! Risk of material damage!**

Below are some obligatory instructions for preventing any material damage!



Below is some advice for use and important information.

## Información general



Esta "Comunicación técnica" deberá estudiarse muy bien **antes** de comenzar los trabajos.



Es obligatorio utilizar protección ocular para todos los trabajos en y con el reloj.



ETA SA no se hace responsable de los daños provocados como consecuencia de la inobservancia de esta "Comunicación técnica".

## Normas de protección medioambiental



**Deberá cumplirse la normativa legal relativa al reciclaje y la eliminación correctos de los residuos en todos los trabajos en y con el reloj.**

En especial, deberán eliminarse correctamente los productos lubricantes y de limpieza peligrosos para el medio ambiente.



**Las sustancias contaminantes del agua** deben recogerse, almacenarse, transportarse y eliminarse en recipientes adecuados.

**En ningún caso se permitirá que contaminen el suelo o que lleguen a la canalización.**

## Significado de los símbolos



**Atención Peligro de daños materiales**

Instrucciones que deberán respetarse necesariamente para evitar daños materiales.



Consejos de aplicación e información importantes.

## Informazioni generali



Questa "Comunicazione Tecnica" deve essere studiata attentamente **prima** dell'inizio dei lavori.



Per tutti i lavori su e con il movimento dell'orologio è obbligatorio proteggere gli occhi!



ETA SA declina qualunque responsabilità per eventuali danni causati dalla mancata osservanza della presente "Comunicazione tecnica".

## Disposizioni relative alla protezione ambientale



**Per tutti i lavori su e con il movimento dell'orologio si dovranno rispettare le disposizioni di legge relative al corretto riciclaggio e smaltimento dei rifiuti!**

In particolare si dovrà provvedere al corretto smaltimento di lubrificanti e detergenti nocivi per l'ambiente!



**Le sostanze inquinanti per l'acqua** devono essere conservate, trasportate, raccolte e smaltite in contenitori adatti.

**Queste non devono inquinare il terreno o arrivare nelle canalizzazioni!**

## Spiegazione dei simboli



**Attenzione! Pericolo di danni materiali!**

Seguono importanti indicazioni che devono essere tassativamente rispettate per evitare danni materiali!



Seguono consigli per l'uso e informazioni importanti.

List of components - Lista de piezas - Lista fornitori

Pos	No	No CS	Article number Número de artículo Numero articolo	List of components	Lista de piezas	Lista fornitori
-	100	10.020.07	Var	Main plate, jewelled	Platina, empedrada	Piastra con pietre
-	105	10.041.07	Var	Barrel bridge, jewelled	Puente de cubo, empedrado	Ponte del bariletto, con pietre
-	110	10.048.07	Var	Train wheel bridge, jewelled	Puente de rodaje, empedrado	Ponte del ruotismo con pietre
-	121/4	10.058.24	Var	Balance bridge for regulator with pointer, for shock-absorber, stud support ETACHRON, corrector	Puente de volante, para raqueta con flecha, amortiguador, porta-pitón ETACHRON y corrector	Ponte del bilanciere, per racchetta, con freccia, ammortizzatore, porta-pitone ETACHRON e correttore
-	125	10.057.07	-	Pallet bridge, jewelled	Puente de áncora, empedrado	Ponte dell'ancora, con pietre
-	144	10.300.00	-	Dial fastener	Sujetador del cuadrante	Ferma-quadrante
-	145	10.106.00	-	Dial support	Soporte de esfera	Supporto del quadrante
-	161	80.400.00	Var	Centre tube	Tubito de centro	Tubo di centro
-	180/1	20.010.00	Var	Movement barrel complete	Cubo completo de máquina	Bariletto completo del movimento
-	185	20.040.00	-	Barrel drum	Tambor de cubo	Tamburo del bariletto
-	190	20.050.00	-	Barrel cover	Tapa de cubo	Coperchio del bariletto
-	195	20.060.00	-	Barrel arbor	Árbol de cubo	Albero del bariletto
-	203	30.012.00	-	Intermediate wheel	Rueda intermedia	Ruota intermedia
-	210	30.025.00	-	Third wheel	Rueda primera	Ruota mediana
-	227	30.027.00	Var	Second wheel	Rueda de segundos	Ruota dei secondi
-	242	31.083.00	Var	Cannon pinion with driving wheel	Cañón de minutos con arrastrador	Pignone calzante con conduttore
-	251	31.047.00	Var	Roue des heures 24 h	Stundenrad 24 Std.	Hour wheel 24 hrs
-	260	31.041.00	-	Minute wheel	Rueda de minutería	Ruota della minuteria
-	303/5	40.302.23	Var	Two-piece regulator, with pointer, for stud support ETACHRON and corrector	Raqueta de 2 piezas, con flecha para porta-pitón ETACHRON y corrector	Racchetta in 2 pezzi, con freccia, per portapitone ETACHRON e correttore
-	358	40.380.00	Var	Regulator corrector	Corrector de raqueta	Correttore della racchetta
-	375	40.200.06	Var	Stud support, ETACHRON	Porta-pitón, ETACHRON, montaje	Portapitone, ETACHRON, montaggio
-	401	51.010.21	Var	Winding stem	Tija de remontuar	Albero di carica
-	407	31.121.00	-	Sliding pinion	Piñón corredizo	Pignone scorrevole
-	410	31.120.00	-	Winding pinion	Piñón de remontuar	Pignone di carica
-	415	31.020.00	-	Ratchet wheel	Rochete	Rocchetto
-	417	31.021.00	-	Intermediate ratchet wheel	Rochete intermedio	Rocchetto intermedio
-	420	31.023.00	-	Crown wheel	Rueda de corona	Ruota a corona
-	425	51.120.00	-	Click	Trinquete	Cricco
-	435	51.050.00	-	Yoke	Báscula de piñón corredizo	Bascula del pignone scorrevole
-	443/1	51.080.06	-	Setting lever, assembled	Tirete, montado	Tiretto, montato
-	445/2	51.091.20	-	Combined setting lever jumper	Muelle flexible de tirete, combinado	Scatto del tiretto, combinato
-	450	31.100.00	-	Setting wheel	Rueda de transmisión	Rinvio
-	453	31.101.00	-	Intermediate setting wheel	Rueda de transmisión intermedia	Rinvio intermedio
-	462	10.062.00	-	Minute train bridge	Puente de rodaje de minutería	Ponte del ruotismo di minuteria
-	498	80.295.00	-	Friction washer	Arandela de fricción	Rondella di frizione
-	511	81.086.00	-	Click plate	Placa de trinquete	Placca del cricco
-	516	31.024.00	-	Intermediate crown wheel	Rueda de corona intermedia	Ruota della corona intermedia
-	705	30.040.00	-	Escape wheel	Rueda de escape	Ruota di scappamento
-	710	40.010.00	-	Pallet fork	Áncora	Ancora
-	721	40.050.21	Var	Timed annular balance, for shock-absorber and stud support ETACHRON	Volante anular, regulado, para amortiguador y porta-pitón ETACHRON	Bilanciere regolato, per ammortizzatore e portapitone ETACHRON
-	771	20.102.00	-	Mainspring with sliding attachment	Muelle motor con muelle de frenar	Molla-motrice con molla di freno
-	1134	12.030.07	Var	Automatic device framework, jewelled	Marco del dispositivo automático, empedrado	Gabbia del dispositivo automatico, con pietre
-	1141	12.051.07	Var	Automatic device lower bridge, jewelled	Puente inferior del dispositivo automático, empedrado	Ponte inferiore del dispositivo automatico, con pietre
-	1143/1	22.010.06	Var	Oscillating weight, assembled	Masa oscilante, montada	Massa oscillante, montata
-	1481	32.031.00	-	Reduction wheel	Rueda de reducción	Ruota di riduzione
-	1482	32.033.00	-	Ratchet wheel driving wheel	Rueda de arrastre de rochete	Ruota conduttrice del rocchetto
-	1485	52.040.00	-	Reverser	Inversor	Invertitore
-	1488	32.037.00	-	Reversing wheel	Rueda de inversión	Ruota d'inversione
-	1490	32.032.00	-	Intermediate reduction wheel	Rueda intermedia de reducción	Ruota intermedia di riduzione
-	1491	52.120.00	Var	Oscillating weight bolt	Cerrojito de rueda de reducción	Paletto della massa oscillante
-	1497	22.040.00	Var	Ball bearing	Rodamiento de bolillas	Cuscinetto a sfere
-	1514	52.041.00	-	Auxiliary reverser	Inversor auxiliar	Invertitore ausiliario

Pos	No	No CS	Article number Número de artículo Numero articolo		List of components	Lista de piezas	Lista fornitori
-	2535/1	53.250.00	-		Date indicator maintaining small plate	Plaqueta de sujeción del indicador de fecha	Placchetta di guardia dell'indicatore del datario
-	2539	53.022.00	-		Date corrector operating lever	Mando del corrector de fecha	Commando del correttore della data
-	2543	33.011.00	-		Intermediate date wheel	Rueda intermedia de fecha	Ruota intermedia del datario
-	2556	33.020.00	-		Date indicator driving wheel	Rueda de arrastre del indicador de fecha	Ruota conduttrice dell'indicatore della data
-	2557/1	91.440.22	Var		Date indicator	Indicador de fecha	Indicatore della data
-	2558	33.010.00	-		Double-toothed hour wheel	Rueda de horas con doble dentado	Ruota delle ore a doppia dentatura
-	2569	53.204.00	Var		Double corrector	Corrector doble	Correttore doppio
-	2576	53.080.00	-		Date jumper	Muelle flexible de fecha	Scatta-data
-	2595	13.111.00	-		Date jumper maintaining plate	Placa de sujeción del muelle flexible de fecha	Placca di guardia dello scatta-data
-	3024	70.530.00	Var		Jewelled shock-absorber for balance, bottom, to press in, shouldered	Amortiguador, empedrado, de volante, de embutir, de asiento, encima	Ammortizzatore, con pietre, del bilanciere, a pressione, con piano d'appoggio, sopra
-	3025	70.531.00	Var		Jewelled shock-absorber for balance, top, to press in, cylindrical	Amortiguador, empedrado, de volante, de embutir, cilíndrico, debajo	Ammortizzatore, con pietre, del bilanciere, a pressione, cilíndrico, sotto
-	9433	56.070.00	-		Stop lever	Palanquita-stop	Leva stop
-	9565	36.025.00	-		Hour indicator driving wheel	Rueda de arrastre del indicador de horas	Ruota conduttrice dell'indicatore delle ore
-	9712	36.051.00	-		Corrector setting wheel	Rueda de transmisión de corrector	Rinvio correttore
1)	5105	10.041.01	Var	3x	Screw for barrel bridge	Tornillo del puente de cubo	Vite del ponte del bariletto
-	5110	10.048.01	Var	1x	Screw for train wheel bridge	Tornillo de puente de rodaje	Vite del ponte del ruotismo
1)	5121	10.058.01	Var	1x	Screw for balance bridge	Tornillo del puente de volante	Vite del ponte del bilanciere
2)	5125	10.057.01	Var	1x	Screw for pallet bridge	Tornillo del puente de áncora	Vite del ponte d'ancora
2)	5445	51.091.01	Var	1x	Screw for setting lever jumper	Tornillo del muelle flexible de tirete	Vite dello scatto del tiretto
2)	5462	10.062.01	Var	1x	Screw for minute train bridge	Tornillo del puente de rodaje de minutería	Vite del ponte del ruotismo di minutería
-	5462 <sup>1</sup>	10.061.01	Var	1x	Additional screw for minute train bridge	Tornillo del puente de rodaje de minutería suplementario	Vite del ponte del ruotismo di minutería supplementare
-	5511	81.036.01	Var	1x	Screw for click plate	Tornillo de placa de trinquete	Vite della placca del cricco
-	51134	12.030.01	Var	3x	Screw for automatic device framework	Tornillo del marco del dispositivo automático	Vite della gabbia del dispositivo automatico
2)	51141	12.051.01	Var	1x	Screw for automatic device lower bridge	Tornillo del puente inferior del dispositivo automático	Vite del ponte inferiore del dispositivo automatico
-	51497	22.040.01	Var	3x	Screw for ball bearing	Tornillo de rodamiento de bolas	Vite del cuscinetto a sfere
-	52535	53.250.01	Var	1x	Screw for indicator maintaining small plate	Tornillo de plaqueta de sujeción del indicador de fecha	Vite della placchetta di guardia dell'indicatore della data
2)	52595	13.111.01	Var	1x	Screw for date jumper maintaining plate	Tornillo de placa de sujeción del muelle flexible de fecha	Vite della placca di guardia dello scatta-data
3)	59565	36.025.01	-	1x	Screw for hour indicator driving wheel	Tornillo de rueda de arrastre del indicador de horas	Vite della ruota conduttrice dell'indicatore delle ore
3)	59712	36.051.01	-	1x	Screw for hour corrector setting wheel	Tornillo de rueda de transmisión del corrector	Vite del rinvio del correttore
					Identical screws Tornillos idénticos Viti identiche	1) 5105 5121	2) 5125 5445 5462 51141 52595
						3) 59565 59712	
			Var		Variante	Variante	Variant

**Interchangeability and variants can be found on the ETA ONLINE SHOP (EOS):**

[www.eta.ch](http://www.eta.ch)  
→ Support Center  
→ Support Center Portal

**La intercambiabilidad y las variantes se encuentran en ETA ONLINE SHOP (EOS):**

[www.eta.ch](http://www.eta.ch)  
→ Support Center  
→ Support Center Portal

**L'intercambiabilità e le varianti si trovano sul ETA ONLINE SHOP (EOS):**

[www.eta.ch](http://www.eta.ch)  
→ Support Center  
→ Support Center Portal

Materials - Fornituras - Forniture

									5105 5121 Var			
185	190	195	203	210	227 Var	242 Var	251 Var	260	303/5 Var	358 Var	375 Var	5110 Var
401 Var	407	410	415	417	420	425	435	443/1	445/2	5125 5445 5462 51141 52595 Var	5462 <sup>1</sup>	
450	453	462	498	511	516	705	710	721 Var	771	1134 Var	5511 51497 Var	
1141 Var	1143/1 Var	1481	1482	1485	1488	1490	1491 Var	1497 Var	51134 Var	51497 Var	52535	
1514	2535/1	2539	2543	2556	2557/1 Var	2558	2569 Var	2576	59565 59712			
2595	3024 Var	3025 Var	9433	9565	9712							

Order of assembly - Orden del montaje - Ordine dell'assemblaggio:  
 Basic movement - Máquina de base - Movimento di base

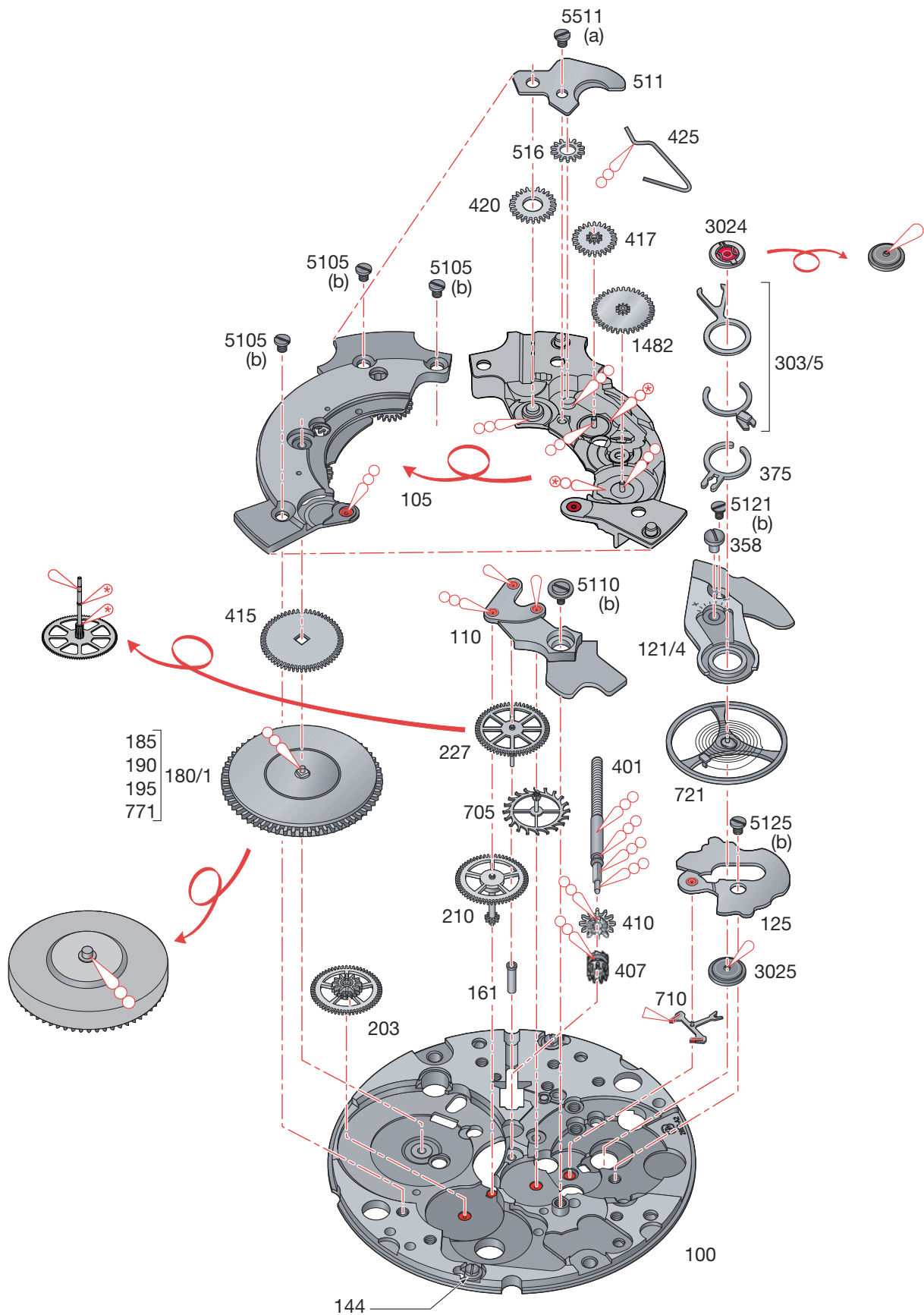

**Assembling of the basic movement**

(Parts listed in order of assembly)

**Montaje de la máquina de base**

(Lista de fornitureas por orden de ensamblado)

**Montaggio del movimento di base**

(Elenco delle forniture in ordine di montaggio)

100	516	5110 (1x)
161	417	710
407	425	125
410	511	5125 (1x)
401	5511 (1x)	358
3025	105	375
203	5105 (3x)	303/5
180/1	705	3024
415	210	721
1482	227	121/4
420	110	5121 (1x)

**Lubrication - Lubricación - Lubrificazione**

 Fine oil  
Aceite fino **Moebius 9010**  
Olio fluido

 Very small quantity  
Cantidad muy pequeña **Moebius 9010**  
Piccolissima quantità

 Thick oil or grease **Moebius HP-1300**  
Aceite espeso o grasa or / ó / o  
Olio denso o grasso **Moebius D5**

 Very small quantity **Moebius HP-1300**  
Cantidad muy pequeña or / ó / o  
Piccolissima quantità **Moebius D5**

 Special oil for pallet stones **Moebius 941**  
Aceite especial para escape or / ó / o  
Olio speciale per scappamento **Moebius 9415**

**M<sub>L</sub> Minimum torque for loosening****M<sub>L</sub> Par mínimo para desatornillar****M<sub>L</sub> Coppia minima per svitare**

- (a) 0,6 Ncm  
(b) 1,2 Ncm

Order of assembly - Orden del montaje - Ordine dell'assemblaggio:  
 Self-winding mechanism - Mecanismo automático - Meccanismo automatico

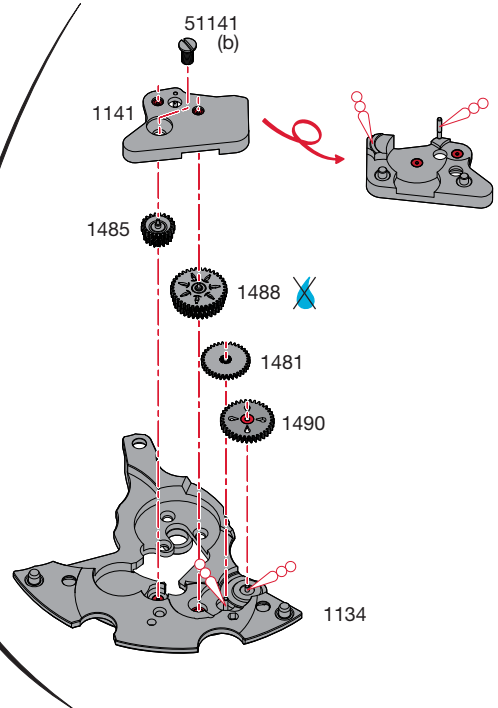
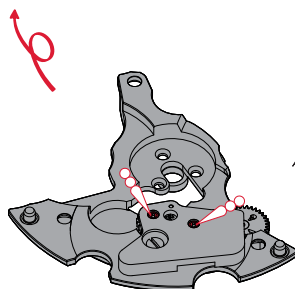
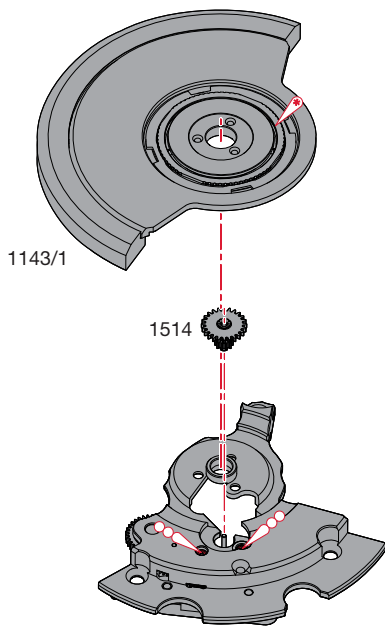
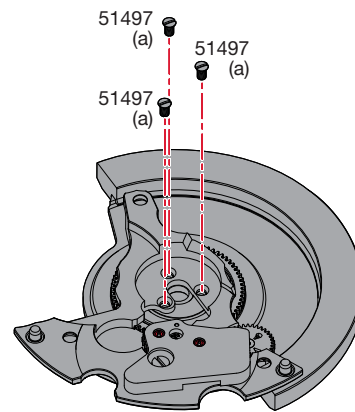
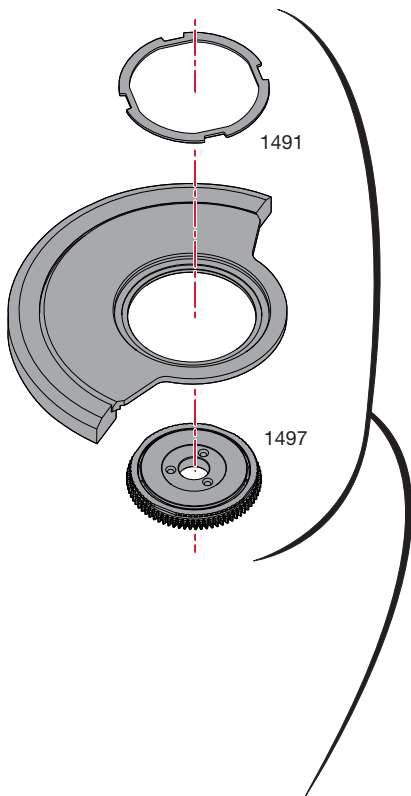



### Assembling of the self-winding mechanism

(Parts listed in order of assembly)

### Montaje del mecanismo automático

(Lista de fornitureas por orden de ensamblado)

### Montaggio del meccanismo automatico

(Elenco delle forniture in ordine di montaggio)

1134	1485	1143/1
1490	1141	51497 (3x)
1481	51141 (1x)	
1488	1514	

### Lubrication - Lubricación - Lubrificazione

Very small quantity



Cantidad muy pequeña  
Piccolissima quantità

**Moebius 9010**

Thick oil or grease



Aceite espeso o grasa  
Olio denso o grasso

**Moebius  
HP-1300  
or / ó / o  
Moebius D5**

Do not wash. If the part is very dirty or rusty, it should be exchanged for an original part which is lubricated and delivered by ETA SA.



Na lavar. Si la pieza está muy sucia o herrumbrosa, cambiar por una forniturea de origen entregada lubricada por ETA SA.

Non lavare. Se il pezzo è molto sporco arrugginito, sostituire con una forniturea di origine fornita lubrificata da ETA SA.

### M<sub>L</sub> Minimum torque for loosening

M<sub>L</sub> Par mínimo para desatornillar

M<sub>L</sub> Coppia minima per svitare

- (a) 0,6 Ncm
- (b) 1,2 Ncm

No 1497:

Only after washing, use very little oil Moebius 9010.



Solamente después lavado, muy pequeña lubricación con Moebius 9010.

Solamente dopo il lavaggio, piccolissima quantità con Moebius 9010.

Order of assembly - Orden del montaje - Ordine dell'assemblaggio:  
Self-winding mechanism - Mecanismo automático - Meccanismo automatico

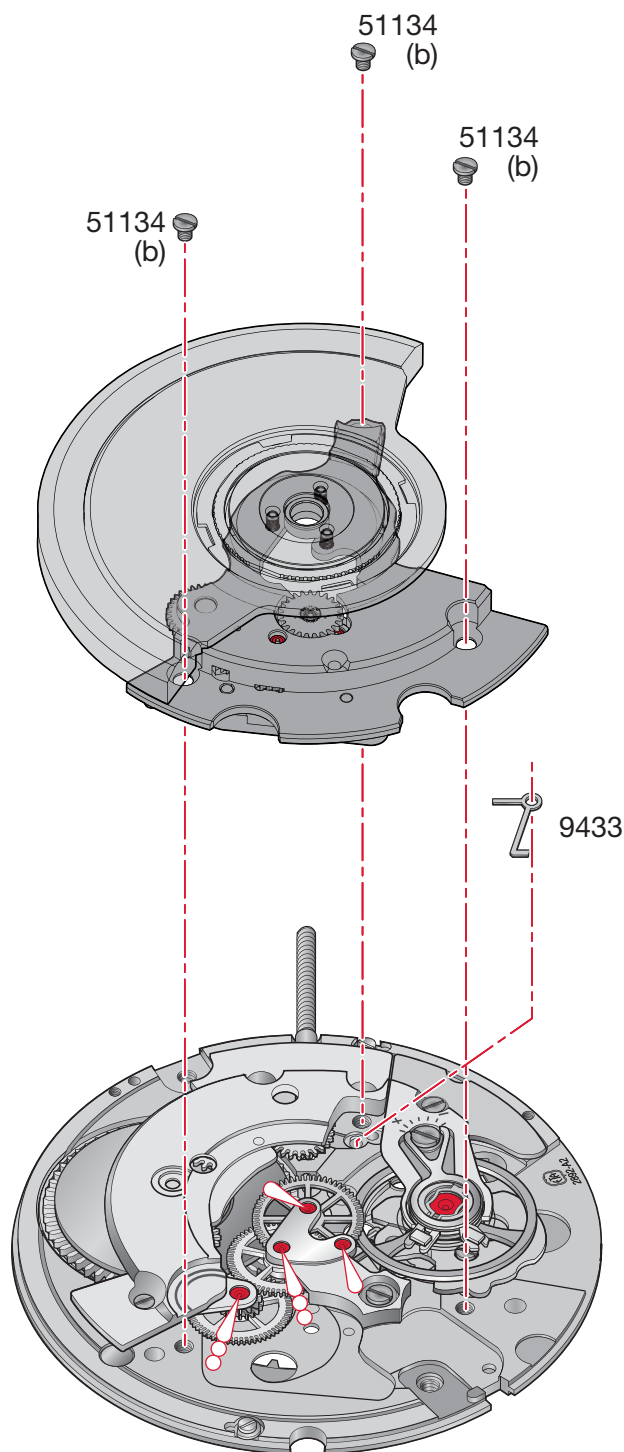

**Assembling of the self-winding mechanism**

(Parts listed in order of assembly)

**Montaje del mecanismo automático**

(Lista de fornitureas por orden de ensamblado)

**Montaggio del meccanismo automatico**

(Elenco delle forniture in ordine di montaggio)

9433

(1134)

51134 (3x)

**Lubrication - Lubricación - Lubrificazione**

Fine oil



Aceite fino

Olio fluido

**Moebius 9010**

Thick oil or grease



Aceite espeso o grasa

Olio denso o grasso

**Moebius****HP-1300**

or / ó / o

**Moebius D5****M<sub>L</sub> Minimum torque for loosening****M<sub>L</sub> Par mínimo para desatornillar****M<sub>L</sub> Coppia minima per svitare**

(b) 1,2 Ncm

Order of assembly - Orden del montaje - Ordine dell'assemblaggio:  
 Date and universal hour mechanism - Mecanismo de fecha y de hora universal - Meccanismo della data e dell'ora universale

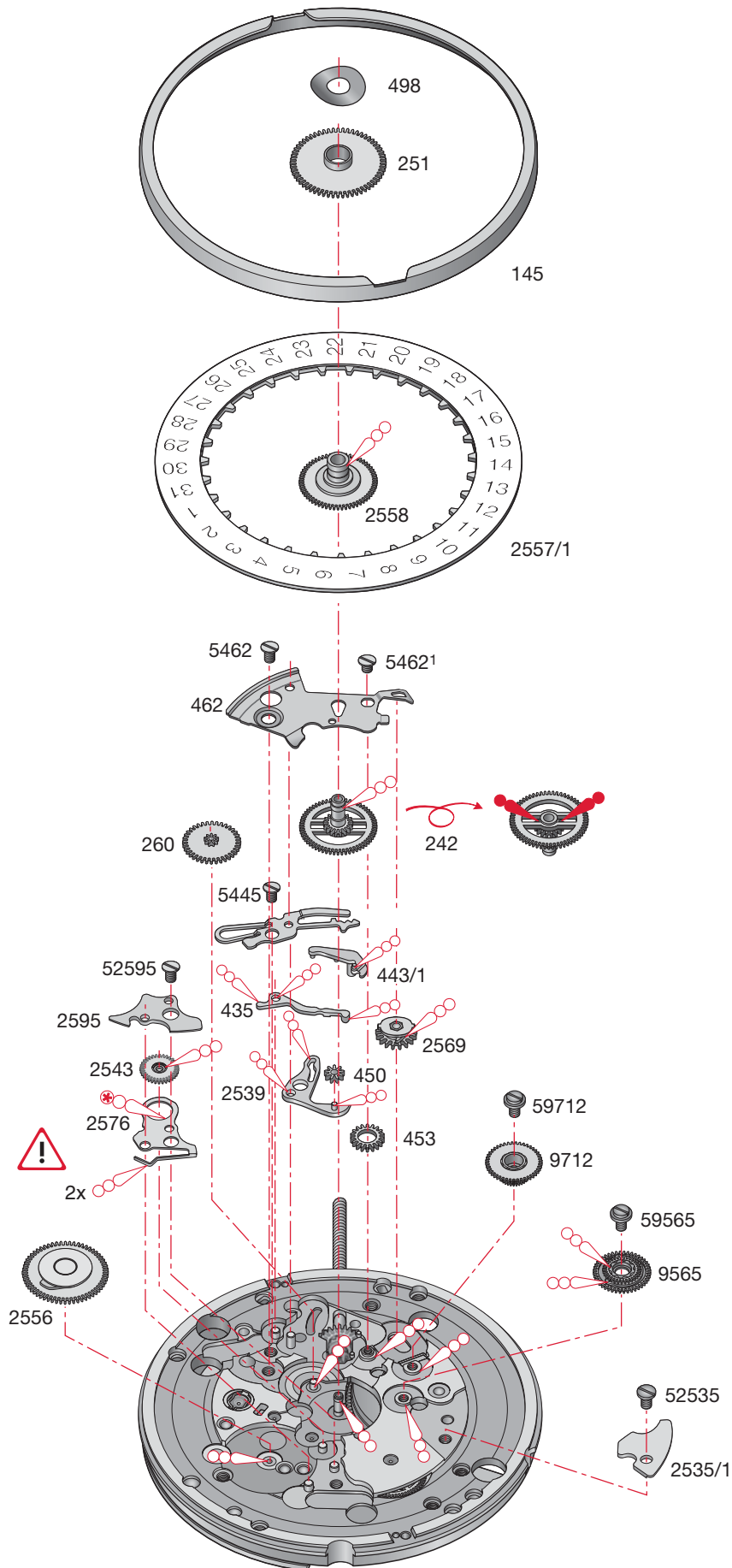

### Assembling of date and 24 hour hand mechanism

(Parts listed in order of assembly)

### Montaje del mecanismo de fecha y aguja 24 horas

(Lista de fornitureas por orden de ensamblado)

### Montaggio del meccanismo della data e lancetta delle 24 ore

(Elenco delle forniture in ordine di montaggio)

2539	462	52595 (1x)
443/1	5462 (1x)	9565
435	5462 <sup>1</sup> (1x)	59565 (1x)
445/2	2556	9712
5445 (1x)	2557/1	59712 (1x)
242	2535/1	2558
260	52535 (1x)	251
450	2543	498
453	2576	145
2569	2595	

**M<sub>L</sub>** Minimum torque for loosening

**M<sub>L</sub>** Par mínimo para desatornillar

**M<sub>L</sub>** Coppia minima per svitare

(a)	0,6	Ncm
(b)	1,2	Ncm

### Lubrication - Lubricación - Lubrificazione

 Grease  
Grasa  
Grasso

**Moebius 9501**  
or / ó / o  
**Jismaa 124**

 Thick oil or grease  
Aceite espeso o grasa  
Olio denso o grasso

**Moebius HP-1300**  
or / ó / o  
**Moebius D5**

 Very small quantity  
Cantidad muy pequeña  
Piccolissima quantità

**Moebius HP-1300**  
or / ó / o  
**Moebius D5**

	Lubricate part 2576. 1. Lubrique la pieza 2576. Lubrificare il pezzo 2576.
	Rotate part 2557/1 approx 10 teeth with rapide correction. 2. Gire la pieza 2557/1 unos 10 dientes con la corrección rápida. Ruotare il pezzo 2557/1 di circa 10 denti con la correzione rapida.
	Lubricate again part 2576. 3. Lubrique de nuevo la pieza 2576. Lubrificare di nuovo il pezzo 2576.
	Rotate part 2557/1 approx 10 teeth with rapide correction again. 4. Gire de nuevo la pieza 2557/1 unos 10 dientes con la corrección rápida. Ruotare di nuovo il pezzo 2557/1 di circa 10 denti con la correzione rapida.

Ajustement aiguille heures universelle  
 Universalzeiger-Passung  
 Universal hand fitting

Ajustement aiguille des heures  
 Stundenzeigerpassung  
 Hour hand fitting

Ajustement aiguille des minutes  
 Minutenzeigerpassung  
 Minute hand fitting

Ajustement aiguille des secondes  
 Sekundenzeigerpassung  
 Second hand fitting

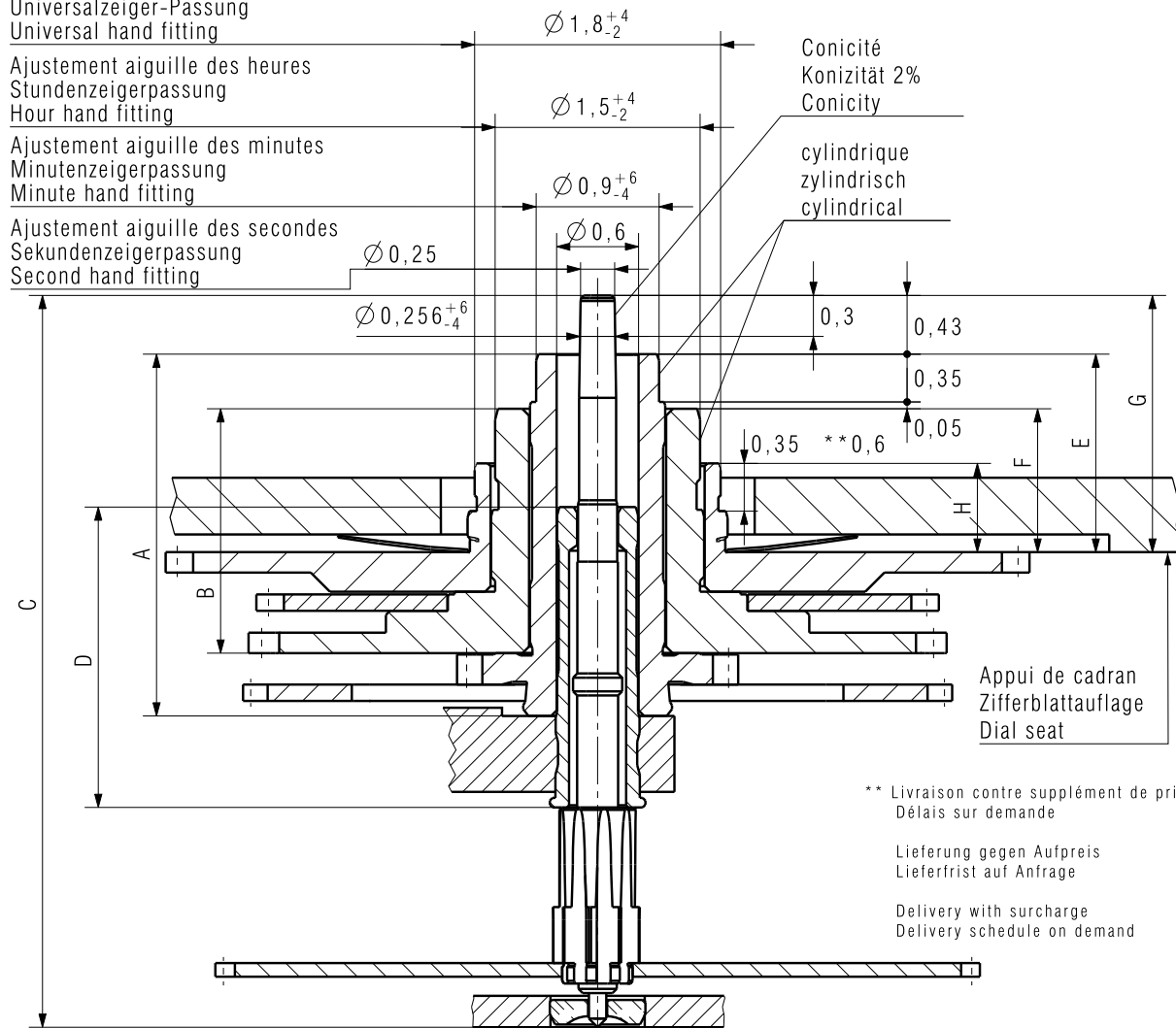

\*\* Livraison contre supplément de prix  
 Délais sur demande

Lieferung gegen Aufpreis  
 Lieferfrist auf Anfrage

Delivery with surcharge  
 Delivery schedule on demand

Aiguillage Zeigerwerkhöhe Hand fitting height	Longueur/Länge/Length					Dépassement Höhe der Zifferblattauflage Height over dial seat				
	A	B	C	J 24H	D	E	F	G	H 24h	
	Chaussée Minutenrohr Cannon-pinion	Roue des heures Stundenrad Hour wheel	Pig. des sec. Sekundentrieb Sec. wheel pin.	Indicat. d'heures Stundenanzeiger Hour indicator	Tube de centre Zentrumrohr Centre tube	Chaussée Minutenrohr Cannon-pinion	Roue des heures Stundenrad Hour wheel	Pig. des sec. Stundenrad Hour wheel	Indicat. d'heures Stundenanzeiger Hour indicator	
4	2,65	1,79	5,36	0,94	2,2	1,45	1,05	1,85	0,65	
5**	2,9	2,04	5,61	1,19	2,2	1,7	1,3	2,1	0,9	
Aiguilles Zeiger Hands						Aiguille d'heure Stundenzeiger Hour wheel	Aiguille de minute Minutenzeiger Minute hand	Aiguille de seconde Sekundenzeiger Second hand		
Masse/Masse/Mass	max. mg									
Balourd/Unwucht/Unbalance	max. µNm									
Force de chasse/Setzkraft/Press-in force	max. N									
Kaliber / Calibre / Caliber 2893-2	Massestab Echelle Scale --				CATIA V5		Masse in mm Dimensions in mm Dimensions in mm Tol. 1/1000 mm			
AIGUILLAGES ZEIGERWERKHÖHEN HAND FITTING HEIGHTS						Z0091649	Version 04	Revision 00	Blatt Feuille Sheet 01/01	
<b>ETA SA</b> MANUFACTURE HORLOGÈRE SUISSE DEPUIS 1793 A COMPANY OF THE <b>SWATCH GROUP</b>			Ersatz für/En remplacement de/Remplacement for Aenderung/Modification 28193			Klass. Class. ZVACC		KUN		
			Erstellt Etabli Created 09.08.2012 ADG			Geprüft Contrôlé Controlled 10.08.2012 HID		Freigegeben Libéré Released 10.08.2012 HID		

We reserve all rights for this document. It is meant for the recipient only and it may not be copied, printed or given to a third person without our written permission. Quedan reservados todos los derechos relacionados con este documento, que está dirigido únicamente al destinatario. Queda por lo tanto prohibida su copia, impresión o nuestra autorización por escrito. Ogni diritto su questo documento è riservato. Il documento è indirizzato esclusivamente al destinatario e non può essere copiato, stampato o ceduto a terzi senza un'autorizzazione scritta.

This page has deliberately been left blank in case of A3 format printing.

Esta página se han dejado en blanco a propósito en caso de imprimirla en formato A3.

Questa pagina è lasciata intenzionalmente bianca in caso di stampa formato A3.

**Modifications compared with previous document versions****Modificaciones comparadas con las versiones anteriores del documento****Modifiche comparate con le versioni precedenti del documento**

Version Versión Versione	Date Fecha Data	Modification	Modificación	Modifica	Page Página Pagina
08	03.09.2012	New drawing	Nuevo plan	Nuevo disegno	14
07	24.05.2012	New drawing	Nuevo plan	Nuevo disegno	14
06	03.04.2012	New address	Nueva dirección	Nuovo indirizzo	1, 4, 16
		New drawing	Nuevo plan	Nuevo disegno	14
05	17.11.2010	Montage	Montaje	Montaggio	6-13
04	03.02.2009	Allocation per caliber	Asignación por calibres	Ripartizione per calibri	--
		Remove parts No 166 and 166/1	Eliminar piezas No. 166 y 166/1	Soppressione dei pezzi No 166 e 166/1	2
		Minimum torque for loosening	Par mínimo para desatornillar	Coppia minima per svitare	6-8
		Addition lubrication	Lubricación adicional	Aggiungere lubrificazione	8
		New drawing	Nuevo plan	Nuovo disegno	9
03	02.04.2007	New layout	Nuevo layout	Nuova layout	1-12
		Basic version	Versión de base	Versione di base	--

All modifications reserved.

Salvo modificación.

Con riserva di ogni eventuale modifica.

This document can be found on the  
Support Center Portal (SCP):

[www.eta.ch](http://www.eta.ch)

- Support Center
- Support Center Portal
- Technical Documents

Este documento se encuentran en el  
Support Center Portal (SCP):

[www.eta.ch](http://www.eta.ch)

- Support Center
- Support Center Portal
- Technical Documents

Il presente documento si trovano sul  
Support Center Portal (SCP):

[www.eta.ch](http://www.eta.ch)

- Support Center
- Support Center Portal
- Technical Documents



**ETA**<sup>SA</sup>  
MANUFACTURE HORLOGÈRE SUISSE  
DEPUIS 1793

SC PRODUCT COMMUNICATION

Bahnhofstrasse 9  
2540 Grenchen  
Switzerland

Phone +41 (0)32 655 71 11  
Fax +41 (0)32 655 71 74

contact@eta.ch  
www.eta.ch